

**PRODUCT
CATALOG**

TMXFLOW

SDD
VERTICAL MIXERS





Options

- DIN2632-pn10 flange or rectangular flange for the assembly on a tank.
- Circulation propeller.
- Downthrust propeller.
- Disintegrating head. Fine screen head.
- Intermediate flange for long mixers.
- SLIM system. Upper suction head.
- Motor shroud.
- Other motor protections.

Application

Vertical mixer series high shear vertical mixers offer a solution for the dispersion, emulsification, homogenization and degradation processes of solids in a wide variety of products in the food processing, cosmetic, pharmaceutical and fine chemical industries.

These mixers are intended for work under the atmospheric pressure and with the products of either high or low viscosity.

The mixers are recommended to work with anchor. Type agitators if the application involves highly viscous media.

Operation

The high speed and adjusted tolerances between the rotor and the stator result in high suction potential, the product is suctioned from the bottom of the tank and driven to the centre of the head.

Passing through the openings of the stator the product is mechanically sheared.

The particles are sheared by the rotor at 20 m/s and finally the product is hydraulically sheared while leaving the stator through the slots at a high speed.

The combination of the vertical suction and radial thrust result in a circulation flow.

User Benefits

- Fast and homogenous powder dissolving
- Fast, effective liquid mixing performance in tanks
- Efficient gas and powder dispersion
- High dynamic shear, gentle mixing
- Reduced installation, emission, energy and maintenance costs.
- Reduced investment cost due to the reduction to basic functions.

Configuration

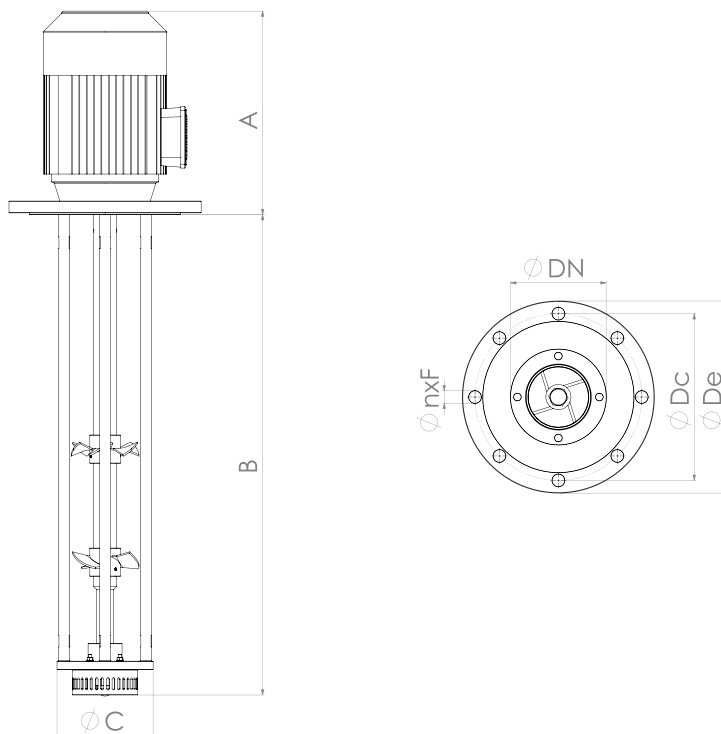

Dimensions

TYPE	Ø Dn	Ø De	Ø Dc	n*f	A	B	C
SDD 30 011	150	250	225	4*11	258	750	125
SDD 30 040	200	310	280	4*13	355	850	170
SDD 30 075	250	360	330	4*13	450	1200	185
SDD 30 185	50	430	390	4*17,5	525	1400	210

Capacity

TYPE	1 cpu	3000 cpu	Additional agitation	Power(kw)	Speed(rpm)
SDD 30 011	300 L	100 L	200 L	1,1	3000
SDD 30 040	500 L	300 L	400 L	4	3000
SDD 30 075	1000 L	750 L	900 L	7,5	3000
SDD 30 185	1500 L	1000 L	1200 L	18,5	3000